

L88 Series

RoHS Directive Products

High Pressure Regulator (Recommended for B₂H₆, NF₃ Service)

Inlet Pressure	Max.24 MPaG (Max.3,480 PSIG)
Outlet Pressure	Max.0.99 MPaG (Max.144 PSIG) (Pressure Range: 0~0.2 MPa, 0~0.4 MPa, 0~0.6 MPa, 0~0.99 MPa)
Supply Pressure Effect	0.00075 MPaG (0.109 PSIG) per 0.1 MPaG (14.5 PSIG)
Proof Pressure	31.5 MPa (4,567 PSIG)
CV	0.10
Temperature	-10°C to +40°C
Outboard Leakage	1×10 ⁻¹¹ Pa·m ³ /sec·He (1×10 ⁻¹⁰ atm·cc/sec·He)
Internal Volume	12.58 cc (0.77 in ³) w/o fittings
Approximate weight	2.4 kg (5 lbs. 5 oz.)
Installation	Threaded holes on the rear surface or Panel mounting

[NOTE]

1MPa = 10.2 kgf/cm² = 145.04 PSI

1MPa = 7504.36 mmHg = 295.4 inHg



Cross sectional drawing

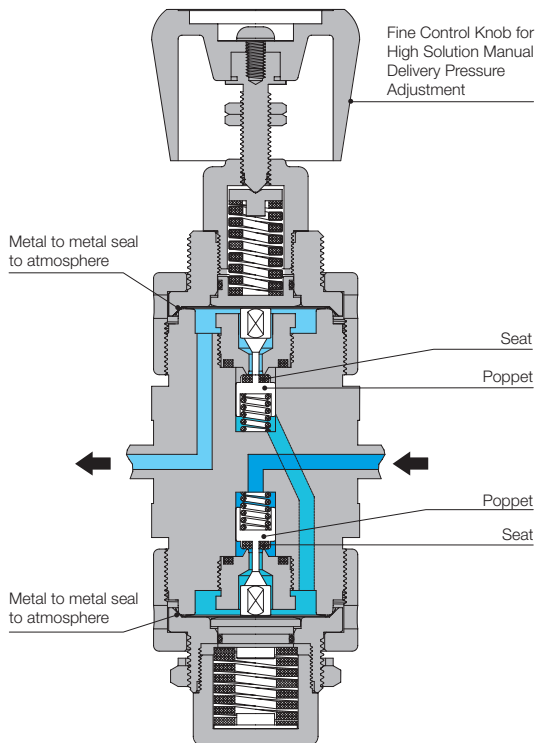

[NOTE]

- Avoid turning the control knob excessively.
- No filter in this unit.

Flow characteristics

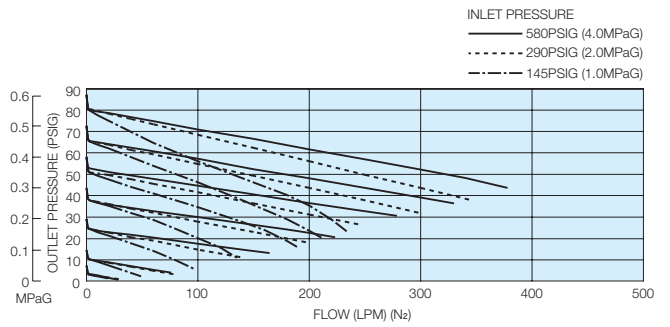

[NOTE]

- These tests were performed at ambient conditions.

Outline drawing

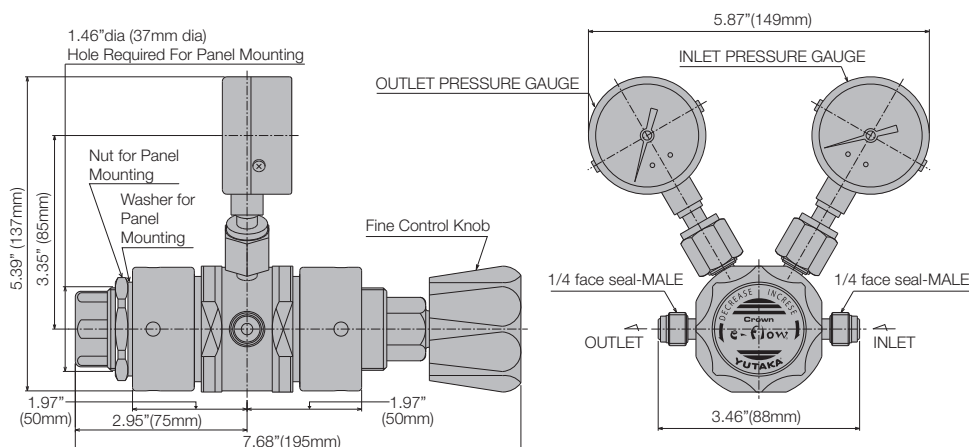

[NOTE]
 · Dimensions are in inches and (mm) for reference only.
 · Subject to change without notice.

Materials of construction

MODEL & TYPE	L88SS	L88SH
Wetted Parts		
Body	SUS316L	
Poppet & Seat Retainer	SUS316L	Hastelloy® C-22
Diaphragm	Hastelloy® C-22	
Seat	PTFE	
Spring	SUS316	
Gasket to seal for gauge	Ni	
Non-wetted Parts		
Bonnet	SUS316	
Control Knob	ABS Resin	
O-ring	NBR	

Wetted surface finishes

Standard Ra (GRADE "B")	32µin. (0.80µm) or less
Optional Ra (GRADE "A")	7µin. (0.18µm) or less

Standard connections

1/4" face to face length of the male and female are the same. (Male) 3.46in. (88mm)
 1/4" face to face length of the male and female are the same. (Female) 4.13in. (105mm)

[NOTE]
 · Any combination of Face Seal male and/or female fittings are available for inlet and outlet.
 · Size and configuration of pressure gauge port is 1/4" Face Seal male.

Ordering information

